

# Rittal – The System.

Faster – better – everywhere.

## Schwenkrahmen, groß Swing frame, large Cadres pivotants grand format

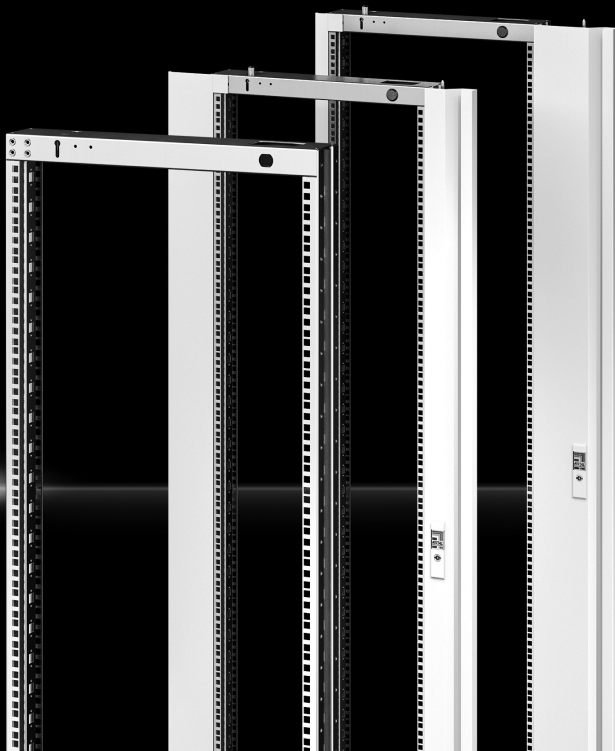

VX 8619.010	VX 8619.021	VX 8619.033
VX 8619.011	VX 8619.022	VX 8619.034
VX 8619.012	VX 8619.023	VX 8619.040
VX 8619.013	VX 8619.024	VX 8619.041
VX 8619.014	VX 8619.030	VX 8619.042
VX 8619.020	VX 8619.032	VX 8619.050

Montage- und Bedienungsanleitung  
Assembly and operating instructions  
Notice de montage et d'emploi

ENCLOSURES

POWER DISTRIBUTION

CLIMATE CONTROL

IT INFRASTRUCTURE

SOFTWARE & SERVICES

FRIEDHELM LOH GROUP



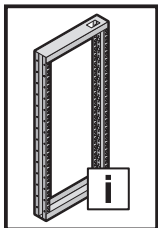

**Inhaltsverzeichnis**  
**Contents**  
**Sommaire**

DE	Seite	EN	Page	FR	Page
<b>1. Sicherheitshinweise</b>	<b>3 – 6</b>	<b>1. Safety instructions</b>	<b>3 – 6</b>	<b>1. Consignes de sécurité</b>	<b>3 – 6</b>
<b>2. Gerätebeschreibung</b>	<b>7</b>	<b>2. Device description</b>	<b>7</b>	<b>2. Description du cadre pivotant</b>	<b>7</b>
2.1 Lieferumfang	7	2.1 Scope of delivery	7	2.1 Composition de la livraison	7
<b>3. Montage und Aufstellung</b>	<b>8 – 17</b>	<b>3. Assembly and siting</b>	<b>8 – 17</b>	<b>3. Montage et implantation</b>	<b>8 – 17</b>
3.1 Einbausatz für Schwenkrahmen, groß	8	3.1 Installation kit for swing frame, large	8	3.1 Kit de montage pour cadre pivotant grand format	8
3.2 Befestigung Einbausatz	9	3.2 Attaching the installation kit	9	3.2 Fixation du kit de montage	9
3.3 Einbau Schwenkrahmen, groß	10	3.3 Installing the swing frame, large	10	3.3 Intégration du cadre pivotant grand format	10
3.4 Einbau 180°-Scharnier (8619.050)	11 – 12	3.4 Mounting the 180° hinge (8619.050)	11 – 12	3.4 Montage des charnières à 180° (8619.050)	11 – 12
3.5 Verschlusswechsel bei Anschlagwechsel	13	3.5 Changing the lock when swapping the hinge	13	3.5 Changement de serrure en cas de changement du sens d'ouverture de la porte	13
3.6 Montage Einbausatz Schwenkrahmen auf Chassis	14	3.6 Installing the swing frame mounting kit on a punched section	14	3.6 Montage avec kit de montage pour cadre pivotant sur rails de montage	14
3.7 Einbaumöglichkeiten	15	3.7 Installation options	15	3.7 Possibilités de montage	15
<b>4. Transport</b>	<b>16</b>	<b>4. Transport</b>	<b>16</b>	<b>4. Transport</b>	<b>16</b>

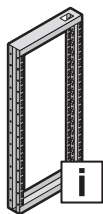

3 – 7  
18 – 19

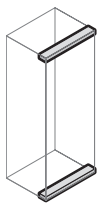

8 – 9

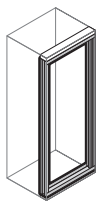

10

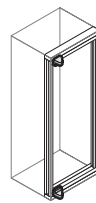

11 – 12

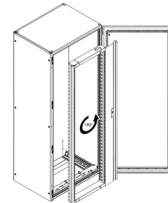

13

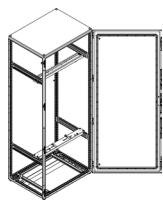

14

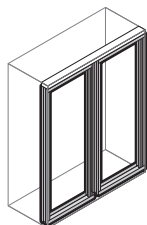

15

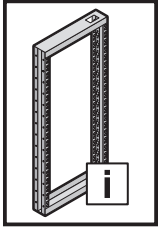

**1. Sicherheitshinweise**  
**1. Safety instructions**  
**1. Consignes de sécurité**

**1. Veiligheidsvoorschriften**  
**1. Säkerhetsinstruktioner**  
**1. Avvertenze di sicurezza**

**1. Advertencias de seguridad**

	DE	EN	FR	NL	SE	IT	ES
	Warnung vor der Schließbewegung von mechanischen Teilen einer Maschine/Einrichtung	Warning against closing movements for mechanical parts of a machine/device	Danger dû à la fermeture de pièces mécaniques d'une machine / installation	Waarschuwing voor de sluitbeweging van mechanische onderdelen van een machine/voorziening	Varning för stängningsrörelse på mekaniska delar i en maskin/enhet	Prestare attenzione alla chiusura delle parti meccaniche di una macchina o di un dispositivo	Atención, movimiento de cierre de componentes mecánicos en una máquina/instalación
	Warnung vor sich bewegenden mechanischen Teilen	Warning against independently moving parts	Danger dû à des pièces mécaniques mobiles	Waarschuwing voor bewegende mechanische onderdelen	Varning för röriga mekaniska delar	Prestare attenzione alle parti meccaniche in movimento	Atención, componentes mecánicos en movimiento
	Warnung vor Umkippen durch Schwerpunktverlagerung	Risk of tipping due to displacement of centre of gravity	Attention au basculement lors du déplacement du centre de gravité	Waarschuwing voor kantelen als gevolg van zwaartepuntverschuiving	Varning för vältande föremål på grund av förskjutet tyngdpunkt	Pericolo di cadute tramite lo spostamento del baricentro	Advertencia de vuelco si se desplaza el centro de gravedad
	Warnung vor spitzem Gegenstand	Caution: Sharp object	Attention aux objets pointus	Waarschuwing voor scherp gepunte voorwerpen	Varning för vassa föremål	Pericolo oggetto affilato	Advertencia de objetos puntiagudos
	Warnung vor Hindernissen am Boden	Caution: Obstructions on floor	Attention aux obstacles au sol	Waarschuwing voor obstakels op de grond	Varning för hinder på marken	Pericolo ostacolo in basso	Advertencia de obstáculos en el suelo
	Warnung vor schweren Lasten	Caution: Heavy loads	Attention aux charges lourdes	Waarschuwing voor zware belastingen	Varning för tung last	Pericolo carichi pesanti	Advertencia de cargas pesadas
	Warnung vor Hindernissen im Kopfbereich	Caution: Obstructions in head area	Attention aux obstacles au niveau de la tête	Waarschuwing voor obstakels op hoofdhoogte	Varning för hinder i huvudhöjd	Pericolo ostacolo in alto	Advertencia de obstáculos en la zona de la cabeza
	Aufsteigen auf eine Fläche ist verboten	Climbing on surfaces is prohibited	Il est interdit de marcher sur toute surface	Het is verboden het oppervlak te betreden	Förbjudet att stå på maskinens ytor	Divieto di salire sulla superficie	Prohibido subirse a una superficie
	Installation durch Elektro-Fachkraft	Installation by specialist electricians	Installation par un électricien confirmé	Installatie door elektrotechnisch personeel	Ska installeras av behörig elektriker	L'installazione deve essere eseguita da un elettricista qualificato	Instalación a realizar por un técnico electricista cualificado
	Installation durch Mechanik-Fachkraft	Installation by specialist mechanics	Installation par un mécanicien confirmé	Installatie door monteur	Ska installeras av behörig montör	L'installazione deve essere eseguita da un meccanico qualificato	Instalación a realizar por un técnico mecánico cualificado

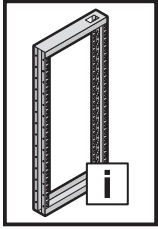

**1. Turvallisuusohjeet**  
**1. Sikkerhedsanvisninger**  
**1. Faisnéis sábháilteachta**

**1. Wskazówki dotyczące bezpieczeństwa**  
**1. Bezpečnostní pokyny**

**1. Инструкции за безопасност**  
**1. Меры безопасности**

	FI	DK	IE	PL	CZ	BG	RU
	Varoitus koneen/ laitteen mekaanisten osien sulkuliikkeestä	Advarsel mod lukkebevægelse af mekaniske dele i en maskine/ indretning	Rabhadh: Gluaiseacht dúnta comhpháirteanna meicniúcha meaisín/gléis	Uwaga na zamykające się części mechaniczne maszyny lub urządzenia	Výstraha před rizikem úrazu ruky	Предупреждение за движение от затварящи се механични части на машина/ оборудване	Предупреждение об опасности при закрывании механических частей машины/ установки
	Varoitus liikkuvista mekaanisista osista	Advarsel mod uafhængigt bevægelige dele	Rabhadh: Comhpháirteanna meicniúla gluaiseachta	Uwaga na ruchome części mechaniczne	Výstraha; Rozmačkání	Предупреждение за движещи се механични части	Предупреждение об опасности движущихся механических частей
	Varo painopisteen siirtymisestä johtuva kaatumisvaara	Risiko for væltning på grund af forskydning af tyngdepunktet	Riosca titime má dhéantar an meáchanlár a dhíláithriú	Ostrzeżenie przed przewróceniem się z powodu przesunięcia środka ciężkości	Varování před převrácením způsobeným posunutím těžiště	Предупреждение за опасност от преобръщане поради изместване на центъра на тежестта	Предупреждение об опрокидывании ввиду смещения центра тяжести
	Varo teräviä esineitä	Advarsel: Spidse genstande	Aire: Rud géar	Ostrzeżenie przed ostrym przedmiotem	Varování před ostrým předmětem	Предупреждение за опасност от остър предмет	Предупреждение об остром предмете
	Varo kompastumisvaara	Advarsel: Forhindringer på gulvet	Aire: Baic ar an urlár	Ostrzeżenie przed przeszkodami na podłożu	Varování před překážkami na zemi	Предупреждение за опасност от препятствия по земята	Предупреждение о препятствиях на полу
	Varo raskasta kuormaa	Advarsel: Tunge belastninger	Aire: Ualái troma	Ostrzeżenie przed dużymi ciężarami	Varování před těžkými břemeny	Предупреждение за опасност от тежки товари	Предупреждение о тяжелых нагрузках
	Varo putoavia esineitä	Advarsel: Forhindringer i hovedhøjde	Aire: Baic i limistéar an chinn	Ostrzeżenie przed przeszkodami w pobliżu głowy	Varování před překážkami v oblasti hlavy	Предупреждение за опасност от препятствия в областта около главата	Предупреждение о препятствиях в верхней области
	Nousu päälle on kielletty	Det er forbudt at klatre på maskinens overflader	Tá cosc ar dhreapadh ar an dromchla	Zakaz wchodzenia na powierzchnię	Nešlapat na povrh	Качването върху повърхностите е забранено	Становится на поверхность запрещается
	Asennuksen saa suorittaa vain sähköalan ammattilainen	Skal installeres af uddannede elektriker	Ní cheadaítear ach amháin do leictreoir cáilithe é a shuiteáil	Instalacja przez elektryka	Instalace vyžaduje elektro odbornost	Монтажът се извършва от електротехник	Установка силами специалистов по электрике
	Asennuksen saa suorittaa vain mekaniikka-alan ammattilainen	Skal installeres af uddannede mekaniker	Ní cheadaítear ach amháin do meicneoir cáilithe é a shuiteáil	Instalacja przez mechanika	Instalace odborným mechanikem	Монтажът се извършва от механик	Установка силами специалистов по механике

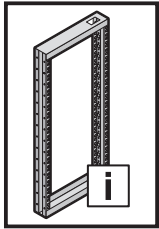

**1. Υποδείξεις ασφαλείας**  
**1. Instrucțiuni de siguranță**  
**1. Sigurnosne upute**

**1. Biztonsági tudnivalók**  
**1. Saugos nurodymai**  
**1. Ohutusteatis**

**1. Drošības prasības**

	GR	RO	HR	HU	LT	EE	LV
	Προειδοποίηση πριν από την κίνηση κλειδώματος μηχανικών μερών μίας εγκατάστασης/ μηχανήματος	Avertizare cu privire la mișcarea de închidere a pieselor mecanice ale unei mașini/ale unui dispozitiv	Upozorenje na uklopno kretanje mehaničkih dijelova stroja/ uređaja	Gép/berendezés mechanikai részeinek zárómozgására történő figyelmeztetés	Įspėjimas dėl mašinos / įrenginio mechaninių dalių judėjimo, užsidarymo metu	Hoiatus masina/ seadme mehhaaniliste osade sulgemisliikumise eest	Uzmanieties iekārtas/mašīnas mehānisko daļu aizvēršanās laikā
	Προειδοποίηση από κινούμενα μηχανικά μέρη	Avertisment cu privire la piesele mecanice aflate în mișcare	Upozorenje na mehaničke dijelove koji su u pokretu	Mozgó mechanikai részekre történő figyelmeztetés	Įspėjimas dėl judančių mechaninių dalių	Hoiatus liikuvate mehhaaniliste osade eest	Uzmanieties no kustīgām mehāniskām daļām
	Προειδοποίηση ανατροπής λόγω μετατόπισης του κέντρου βάρους	Avertizare de răsturnare prin deplasarea centrului de greutate	Upozorenje na prevrtanje zbog pomicanja težišta	Figyelmeztetés a feldőlés veszélyére a súlypont eltolódása miatt	Įspėjimas apie galimą apvirtimą dėl svorio centro perkėlimo	Hoiatus ümberkukkumise eest raskuskeskme nihkumise tõttu	Brīdinājums par apgāšanos smaguma centra novirzīšanās dēļ
	Προειδοποίηση αιχμηρού αντικειμένου	Avertizare privind obiecte ascuțite	Upozorenje na šiljati predmet	Figyelmeztetés hegyes tárgyak veszélyére	Įspėjimas apie aštrų daiktą	Hoiatus terava eseme eest	Brīdinājums par asiem priekšmetiem
	Προειδοποίηση για εμπόδια στο έδαφος	Avertizare privind obstacole la sol	Upozorenje na zapreke na tlu	Figyelmeztetés a padlón található akadályokra	Įspėjimas apie kliūtis ant žemės	Hoiatus põrandal asuvate takistuste eest	Brīdinājums par šķēršļiem uz grīdas
	Προειδοποίηση για βαριά φορτία	Avertizare privind sarcini grele	Upozorenje na teške terete	Figyelmeztetés nehéz teherre	Įspėjimas apie sunkius krovinius	Hoiatus raskete koormate eest	Brīdinājums par lielu slodzi
	Προειδοποίηση για εμπόδια στην περιοχή της κεφαλής	Avertizare privind obstacole în zona capului	Upozorenje na zapreke u području glave	Figyelmeztetés fejmagasságban található akadályokra	Įspėjimas apie kliūtis galvos aukštyje	Hoiatus pea piirkonnas asuvate takistuste eest	Brīdinājums par šķēršļiem galvas zonā
	Απαγορεύεται η ανάβαση σε μία επιφάνεια	Urcarea pe o suprafață este interzisă	Zabranjeno je penjanje na površinu	A felületre lépni tilos	Draudžiama lipti ant paviršiaus	Pinna peale astumine on keelatud	Aizliegts kāpt uz virsmas
	Εγκατάσταση από εκπαιδευμένο ηλεκτρολόγο	Instalarea se va face de un electrician calificat	Instalaciju smije provesti samo ovlašteno stručno osoblje za električarske radove	A szerelését elektromos szakembernek kell elvégeznie	Turi įrengti elektrikas	Kvalifitseeritud elektriku poolne paigaldamine	Uzstādīšanu drīkst veikt tikai kvalificēts elektrīķis
	Εγκατάσταση από εκπαιδευμένο μηχανικό	Instalarea se va face de un mecanic calificat	Instalaciju smije provesti samo ovlašteno stručno osoblje za mehaničarske radove	A szerelését mechanikus szakembernek kell elvégeznie	Turi įrengti mechanikas	Kvalifitseeritud mehhaaniku poolne paigaldamine	Uzstādīšanu drīkst veikt tikai kvalificēts mehāniķis

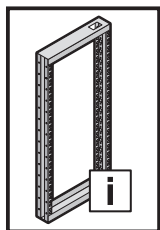

**1. Varnostni napotki**  
**1. Bezpečnostné pokyny**  
**1. Instruções de segurança**

**1. Struzzjonijiet ta' prekawzjoni**

	SI	SK	PT	MT
	Opozorilo pred zapiranjem mehanskih delov stroja/naprave	Dávajte pozor na zatvárací pohyb mechanických částí stroja/zariadenia	Cuidado quando as partes mecánicas de uma máquina/instalação se fecham	Twissija dwar l-gheluq ta' partijiet mekkanici ta' magna/taghmir
	Opozorilo pred premikajočimi se mehanskimi deli	Dávajte pozor na pohyblivé mechanické části	Cuidado com as partes mecánicas móveis	Twissija dwar partijiet mekkanici li jiċcaqluq
	Opozorilo pred prevrnitvijo zaradi spremenjenega težišča	Varovanie pred prevrátením v dôsledku premenenia ťažiska	Cuidado com o risco de queda pelo deslocamento do centro de gravidade	Twissija kontra t-telfien tal-bilanċ minhabba xift tal-gravità
	Opozorilo pred ostrim predmetom	Varovanie pred predmetom s ostrým hrotom	Cuidado com objetos pontiagudos	Twissija kontra oġġett bil-ponta
	Opozorilo pred ovirami na tleh	Varovanie pred prekážkami na podlahe	Cuidado com objetos no chão	Twissija kontra ostakoli mal-art
	Opozorilo pred težkimi bremenami	Varovanie pred ťažkými bremenami	Cuidado com cargas pesadas	Twissija kontra tagħbijiet tqal
	Opozorilo pred ovirami v višini glave	Varovanie pred prekážkami v priestore hlavy	Cuidado com objetos na altura da cabeça	Twissija kontra ostakoli fiż-zona prinċipali
	Vzpenjanje na površino je prepovedano	Je zakázané vystupovať na plošinu	É proibido subir para a superfície	Mhux permess li wiehed jirfes fuq zona
	Namestitev lahko izvajajo samo usposobljeni strokovnjaki za elektrotehnična dela	Inštaláciu smie vykonávať len špecializovaný elektrotechnik	A instalação deve ser feita por um técnico electricista especializado	Installazzjoni minn elettricista kwalifikat/a
	Namestitev lahko izvajajo samo usposobljeni strokovnjaki za mehanična dela	Inštaláciu smie vykonávať len špecializovaný mechanik	A instalação deve ser feita por um técnico mecânico especializado	Installazzjoni minn mekkaniku kwalifikat/a

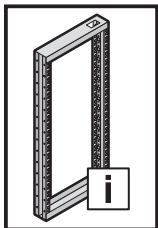

**2. Gerätebeschreibung**  
**2. Device description**  
**2. Description du cadre pivotant**



**2.1 Lieferumfang / 2.1 Scope of delivery / 2.1 Composition de la livraison**

	HE/U				<b>Best.-Nr. VX Model No. VX Référence VX</b>			
					22	<b>8619.010</b>	<b>8619.020</b>	<b>8619.030</b>
					31	<b>8619.011</b>	<b>8619.021</b>	-
					35	<b>8619.012</b>	<b>8619.022</b>	<b>8619.032</b>
					40	<b>8619.013</b>	<b>8619.023</b>	<b>8619.033</b>
					44	<b>8619.014</b>	<b>8619.024</b>	<b>8619.034</b>
		-	2 x	2 x				
	Für Schrankbreite For enclosure width Pour largeur d'armoire	Belastbarkeit N Load capacity N Charge admissible N	VE (St.) Packs of UE (p.)	<b>Best.-Nr. VX Model No. VX Référence VX</b>				
	600 mm	3500	1	<b>8619.040</b>				
	800 mm	3500	1	<b>8619.041</b>				
1200 mm	1500 <sup>1)</sup>	1	<b>8619.042</b>					

<sup>1)</sup> Bei zwei eingebauten Schwenkrahmen gilt eine Gesamtbelastung von 1000 N je Schwenkrahmen.

<sup>1)</sup> For two built-in swing frames, an overall maximum load of 1000 N per swing frame applies.

<sup>1)</sup> Lorsque deux cadres pivotants sont intégrés, il faut tenir compte d'une charge totale maximale de 1 000 N par cadre pivotant.

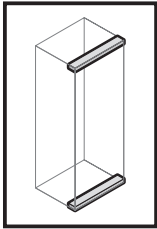

**3. Montage**  
**3. Assembly**  
**3. Montage**



**3.1 Einbausatz für Schwenkrahmen, groß**  
**3.1 Installation kit for swing frame, large**  
**3.1 Kit de montage pour cadre pivotant grand format**

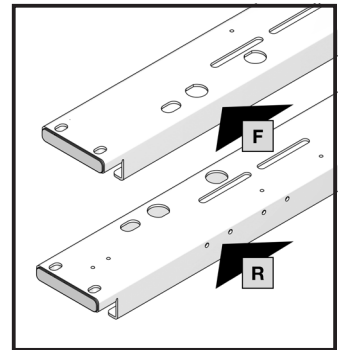
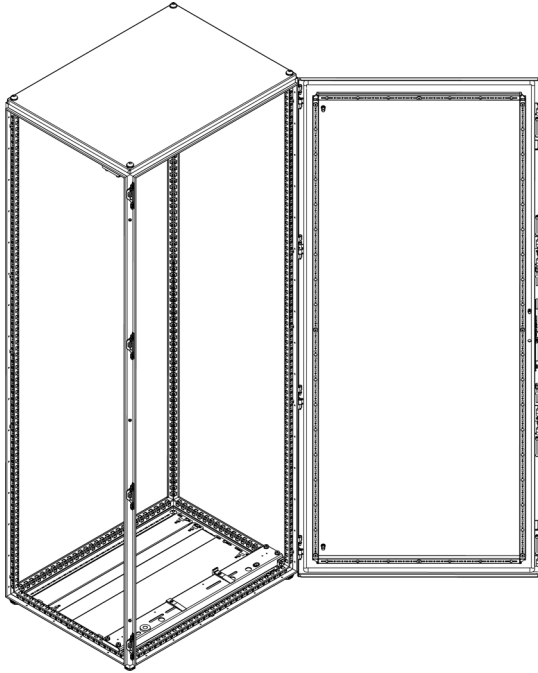

**A** Einbausatz für Schwenkrahmen, groß  
 Installation kit for swing frame, large  
 Kit de montage pour cadre pivotant grand format

Für Schrankbreite mm For enclosure width mm Pour largeur d'armoire mm	Best.-Nr. VX Model No. VX Référence VX
600	8619.040
800	8619.041
1200	8619.042

Schwenkrahmen, groß  
 Swing frame, large  
 Cadres pivotants grand format

HE/U	Best.-Nr. VX/Model No. VX/Référence VX		
	A	B	C
22	8619.010	8619.020	8619.030
31	8619.011	8619.021	-
35	8619.012	8619.022	8619.032
40	8619.013	8619.023	8619.033
44	8619.014	8619.024	8619.034

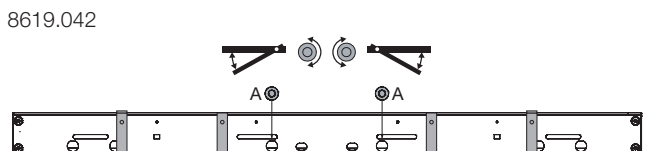
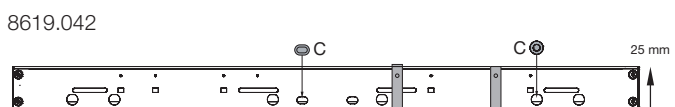
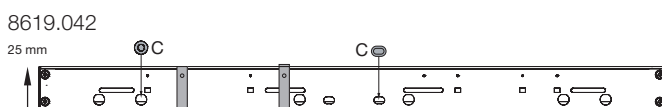
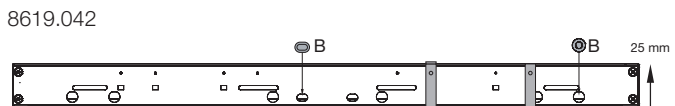
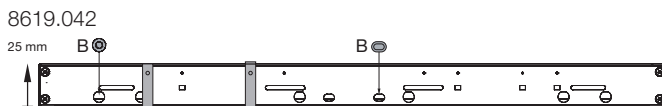
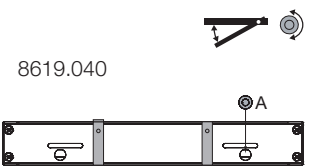
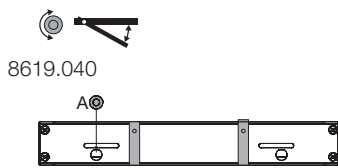



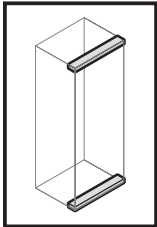

TX15/30



SW13



DE EN FR

3. Montage  
3. Assembly  
3. Montage



3.2 Befestigung Einbausatz  
3.2 Attaching the installation kit  
3.2 Fixation du kit de montage

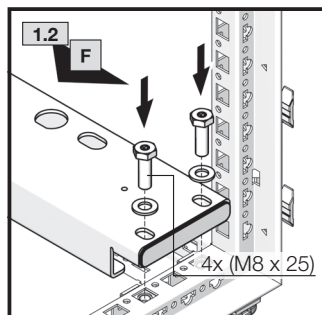
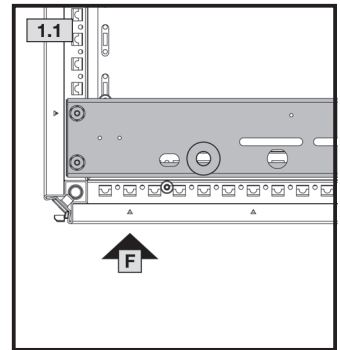
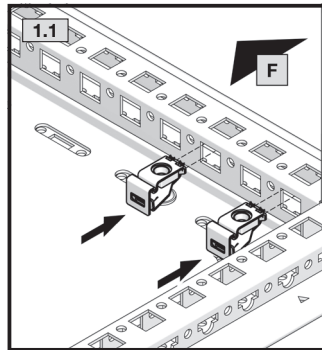
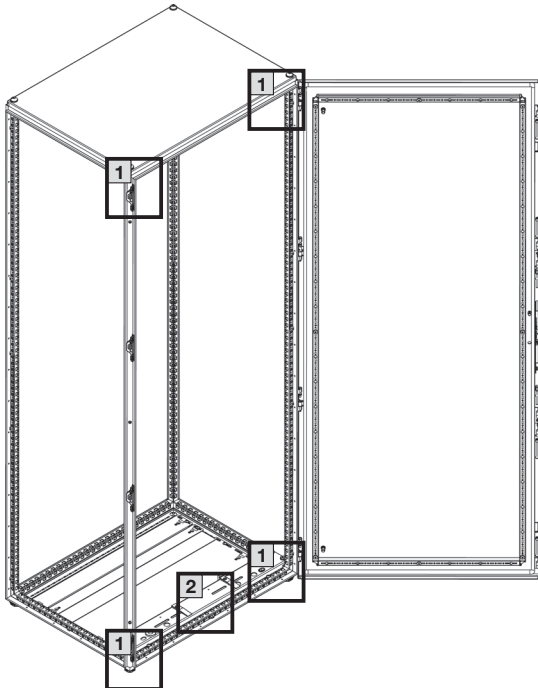

$M_A = 10 \text{ Nm}$

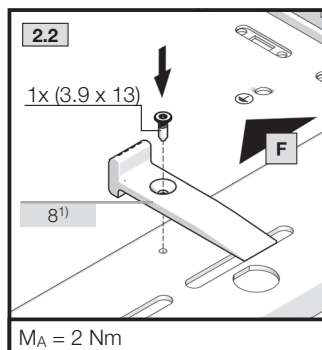
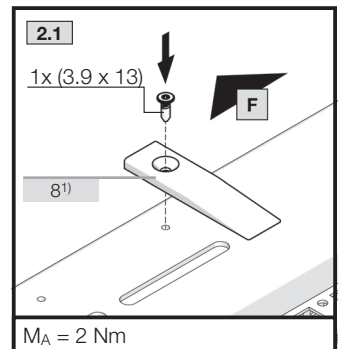
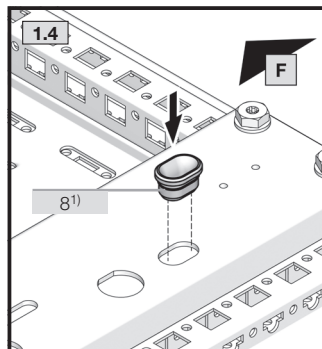
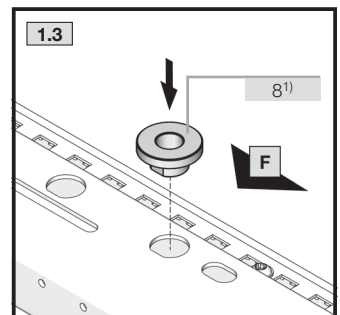

<sup>1)</sup> Informationen zur Positionierung der Bauteile finden Sie auf Seite 8.  
Information on positioning of the components can be found on page 8.  
Les informations concernant le positionnement des pièces figurent en page 8.

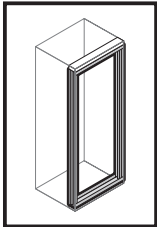

**TX25**



**3. Montage**  
**3. Assembly**  
**3. Montage**



**3.3 Einbau Schwenrahmen, groß**  
**3.3 Installing the swing frame, large**  
**3.3 Intégration du cadre pivotant grand format**

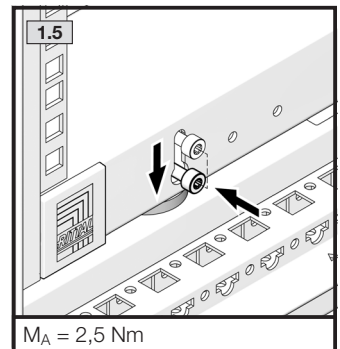
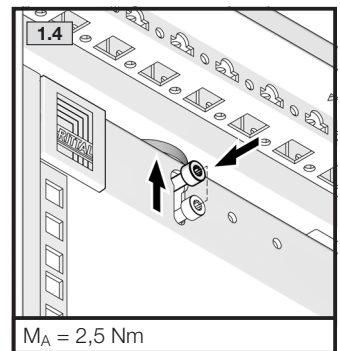
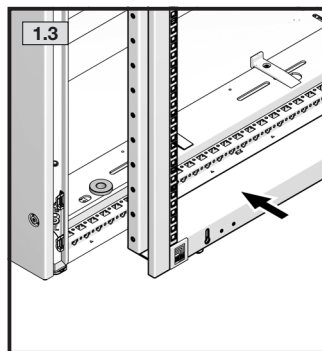
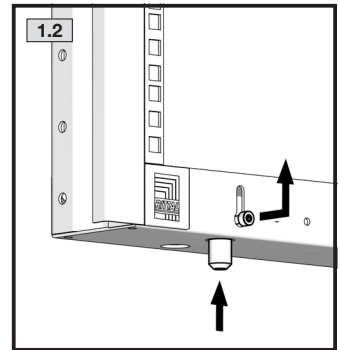
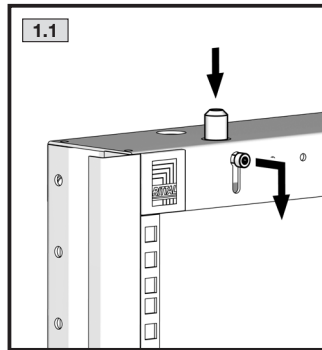
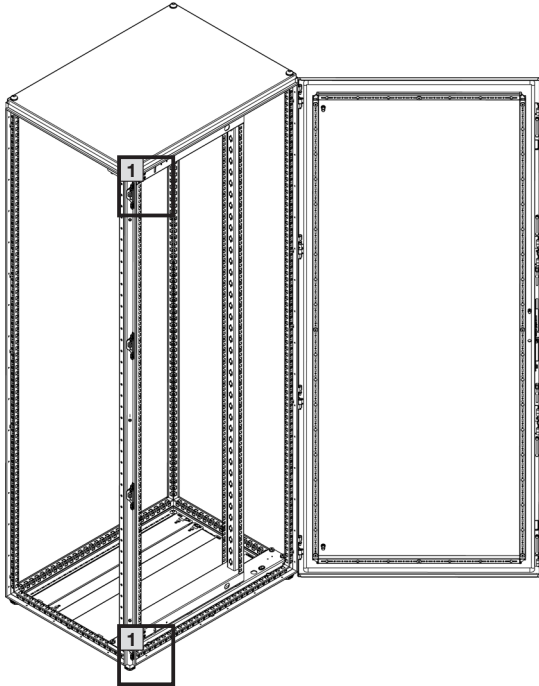

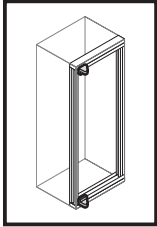

**TX30/40**

**SW13**

DE EN FR

**3. Montage**  
**3. Assembly**  
**3. Montage**



**3.4 Einbau 180°-Scharnier (8619.050)**  
**3.4 Mounting the 180° hinge (8619.050)**  
**3.4 Montage des charnières à 180° (8619.050)**

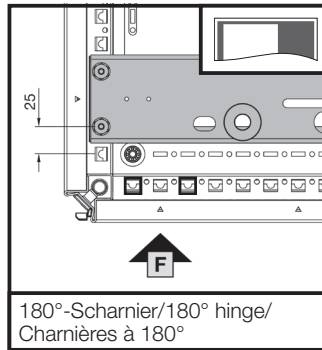
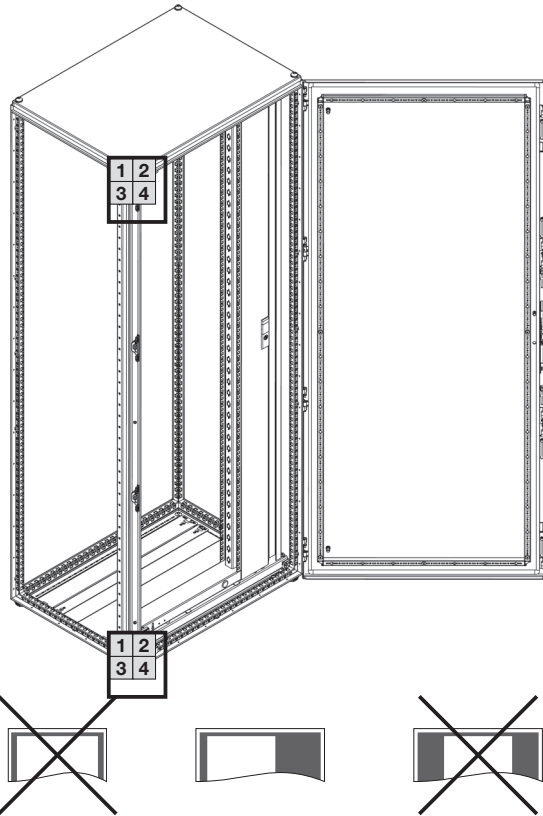

180°-Scharnier/180° hinge/  
Charnières à 180°

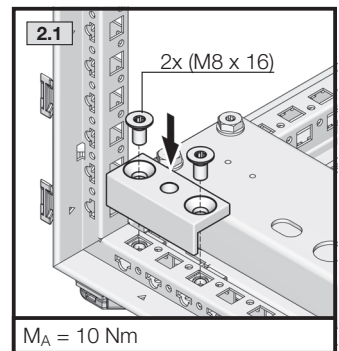
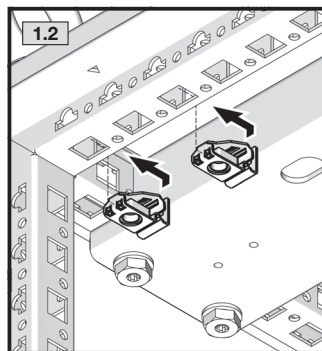
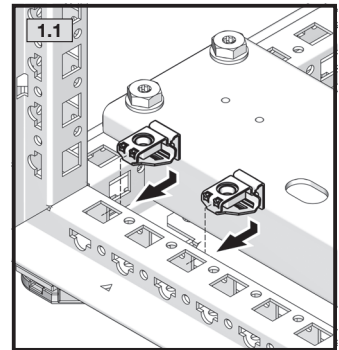

$M_A = 10 \text{ Nm}$

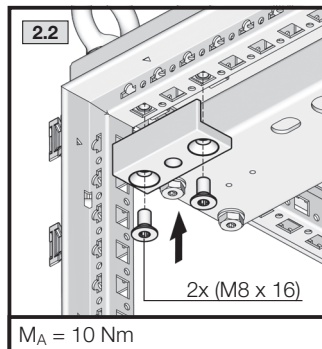

$M_A = 10 \text{ Nm}$

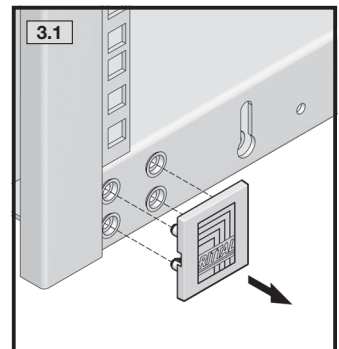

- 1) Schmierfett für Kunststoff/Metall-Paarungen.  
Lubricating grease for plastic/metal combinations.  
Lubrifiante pour combinaisons plastique/métal.

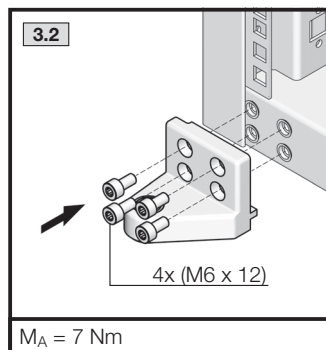

$M_A = 7 \text{ Nm}$

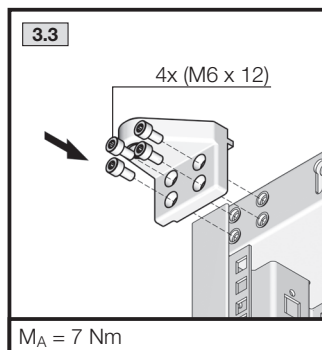

$M_A = 7 \text{ Nm}$

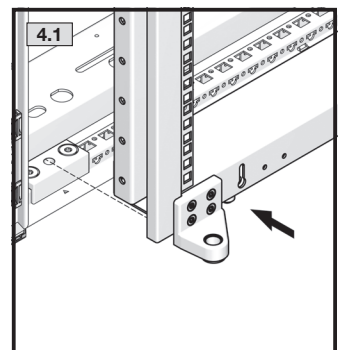

Zum Beispiel / for example / par exemple  
Molykote PG-75

Bei einer Demontage und zweiten Montage ist die Schraubensicherung zu erneuern!

When disassembling and reassembling, the locking screw must be replaced!

Lors du démontage et du remontage, la vis de verrouillage doit être remplacée!

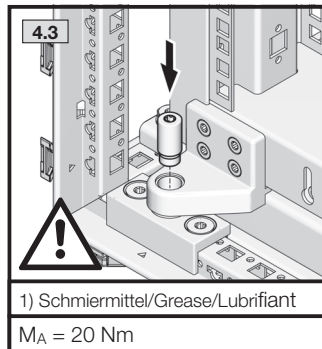
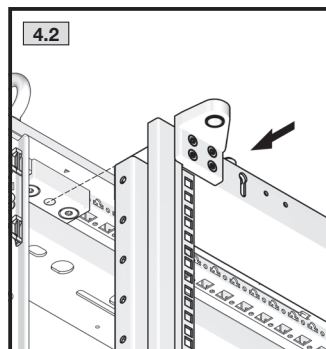

1) Schmiermittel/Grease/Lubrifiant

$M_A = 20 \text{ Nm}$

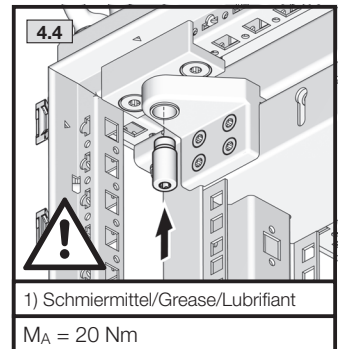

1) Schmiermittel/Grease/Lubrifiant

$M_A = 20 \text{ Nm}$

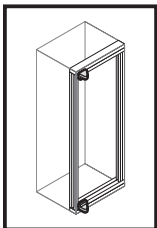

TX30/40



SW13



**3. Montage**  
**3. Assembly**  
**3. Montage**



**3.4 Einbau 180°-Scharnier (8619.050)**  
**3.4 Mounting the 180° hinge (8619.050)**  
**3.4 Montage des charnières à 180° (8619.050)**

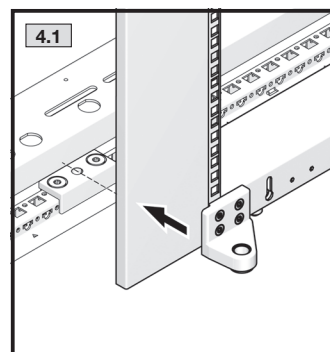
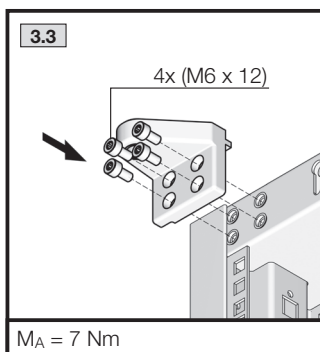
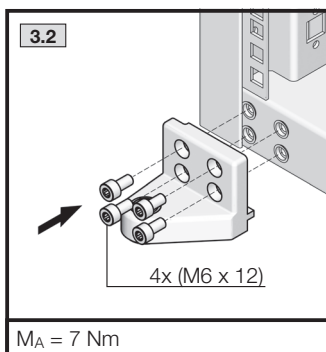
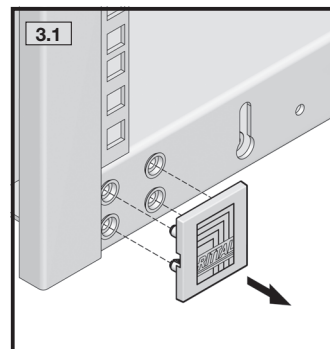
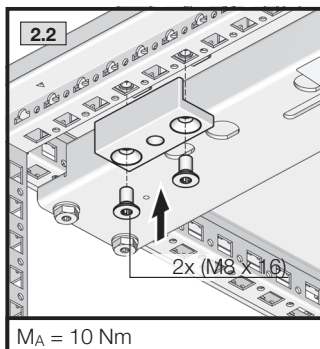
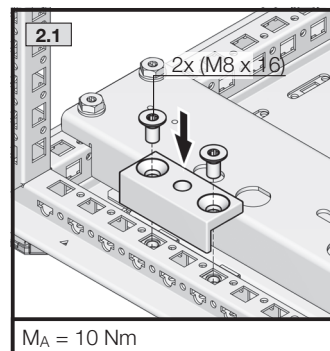
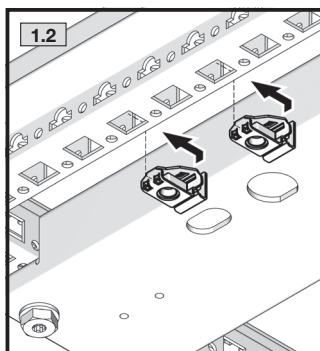
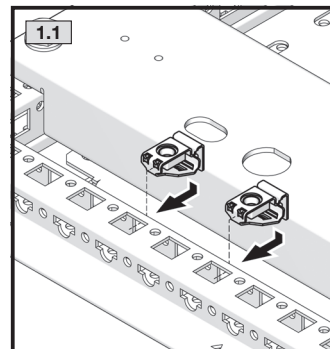
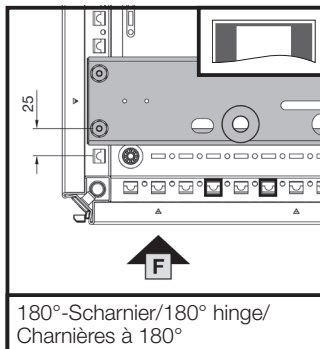
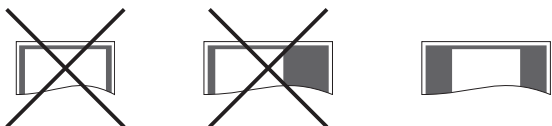
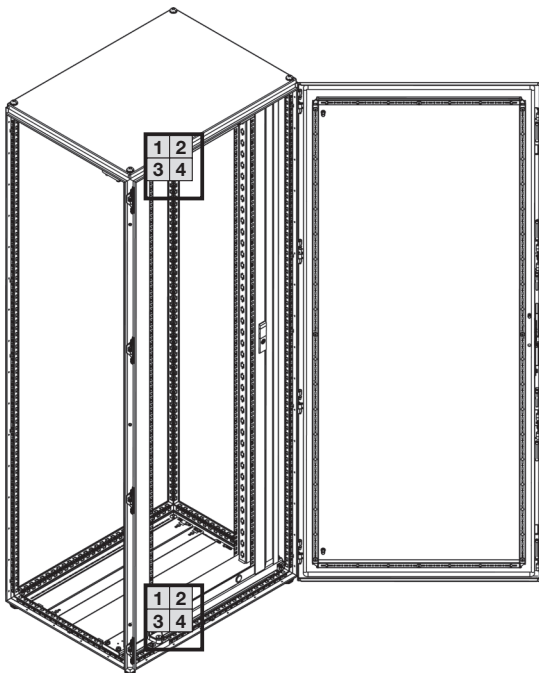

1) Schmierfett für Kunststoff/Metall-Paarungen.  
Lubricating grease for plastic/metal combinations.  
Lubrifiante pour combinaisons plastique/métal.

Zum Beispiel / for example / par exemple  
Molykote PG-75

Bei einer Demontage und zweiten Montage ist die Schraubensicherung zu erneuern!

When disassembling and reassembling, the locking screw must be replaced!

Lors du démontage et du remontage, la vis de verrouillage doit être remplacée!

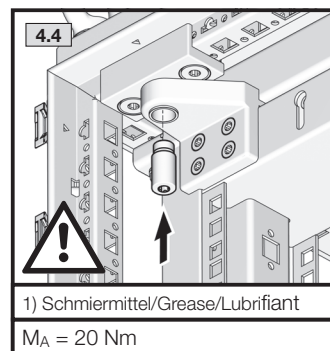
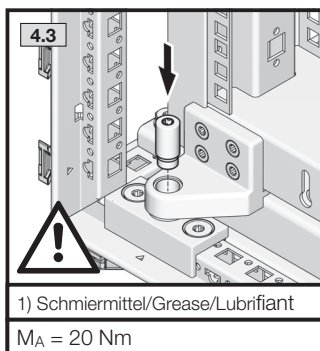
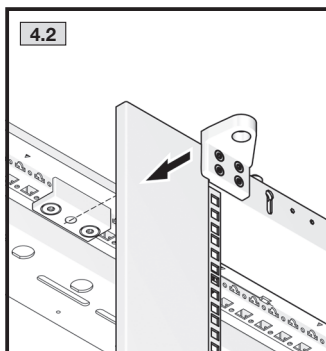

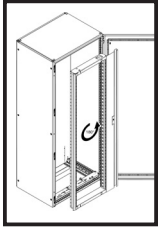

TX25/30

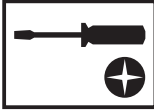

DE EN FR

3. Montage  
3. Assembly  
3. Montage



3.5 Verschlusswechsel bei Anschlagwechsel  
3.5 Changing the lock when swapping the hinge  
3.5 Changement de serrure en cas de changement  
du sens d'ouverture de la porte

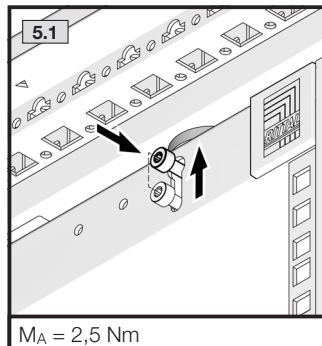
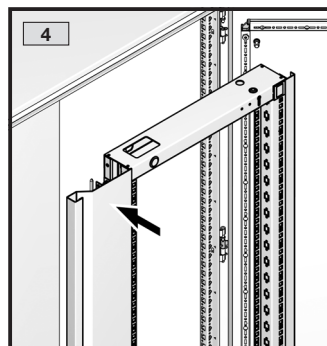
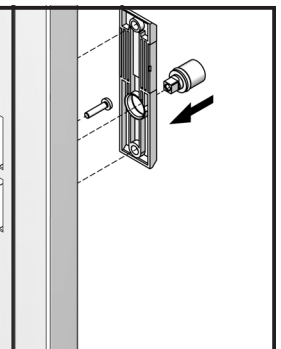
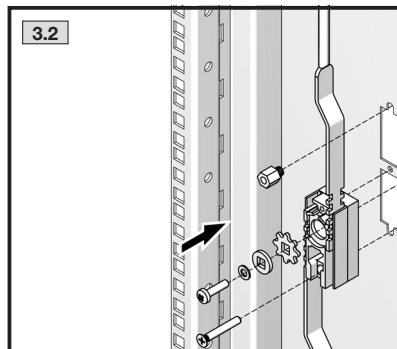
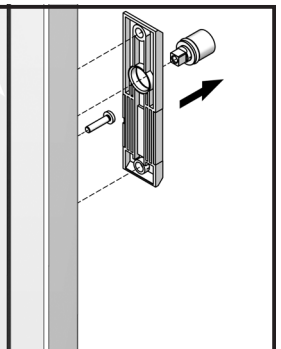
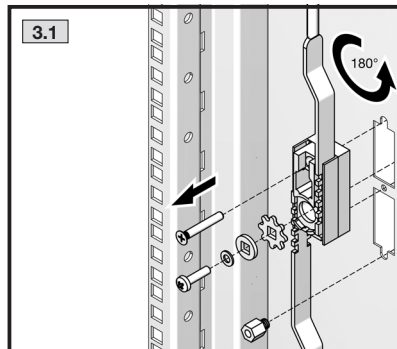
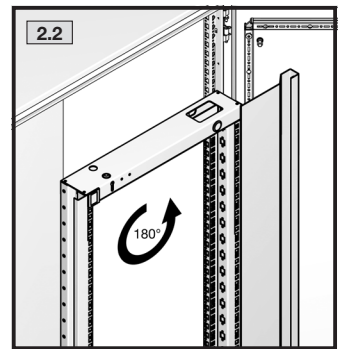
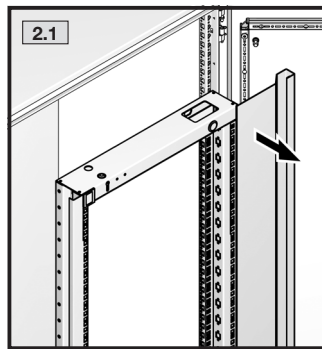
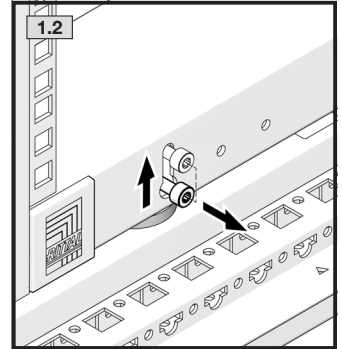
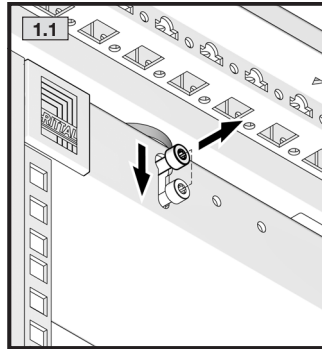
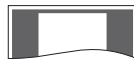
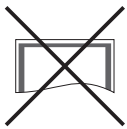
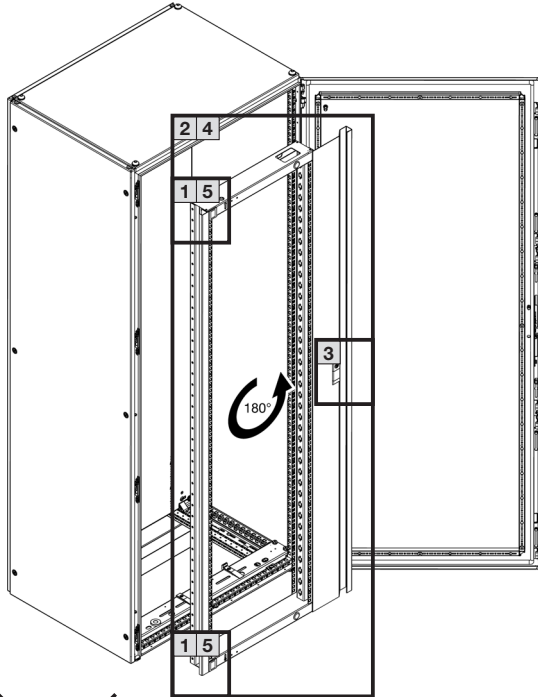

M<sub>A</sub> = 2,5 Nm

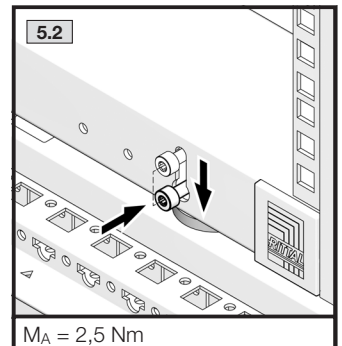

M<sub>A</sub> = 2,5 Nm

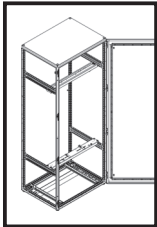

**TX25/30**

**SW13**

DE EN FR

**3. Montage**  
**3. Assembly**  
**3. Montage**



**3.6 Montage Einbausatz Schwenkrahmen auf Chassis**  
**3.6 Installing the swing frame mounting kit on a punched section**  
**3.6 Montage avec kit de montage pour cadre pivotant sur rails de montage**

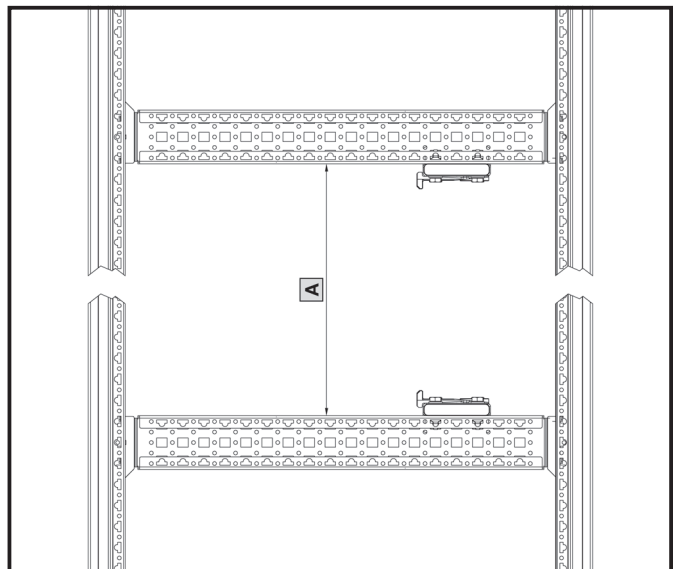
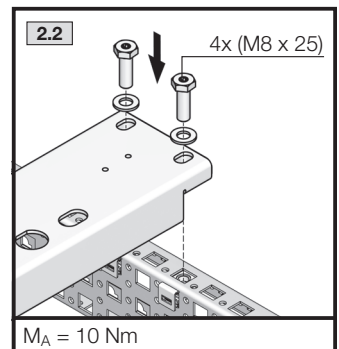
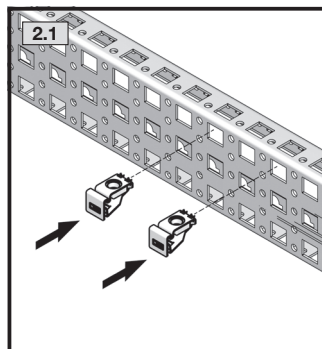
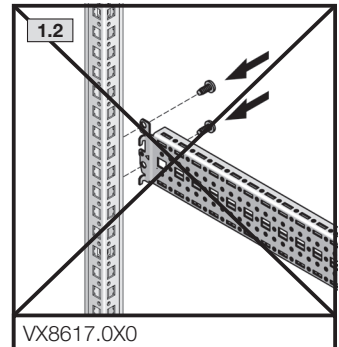
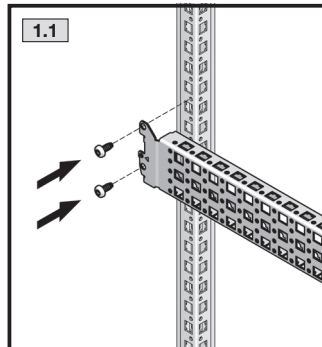
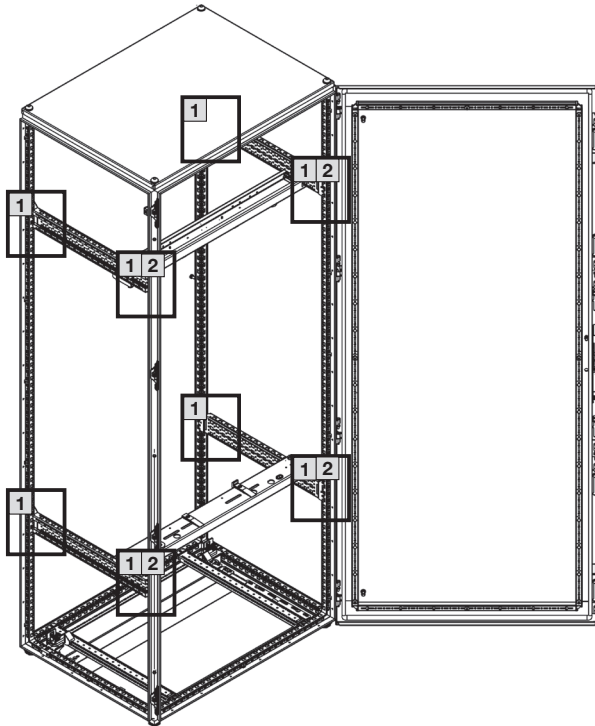

	A mm
22 HE/U/U	1111
31 HE/U/U	1511
35 HE/U/U	1711
40 HE/U/U	1911
44 HE/U/U	2111



**Siehe auch S. 9 – 10**  
**See also page 9 – 10**  
**Voir aussi pages 9 – 10**

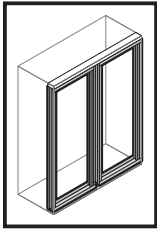

3. Montage  
3. Assembly  
3. Montage



3.7 Einbaumöglichkeiten  
3.7 Installation options  
3.7 Possibilités de montage

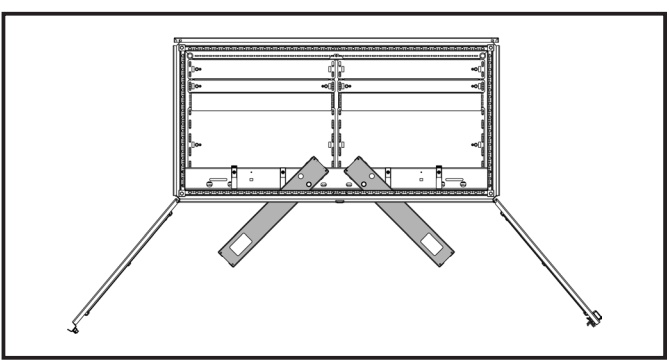
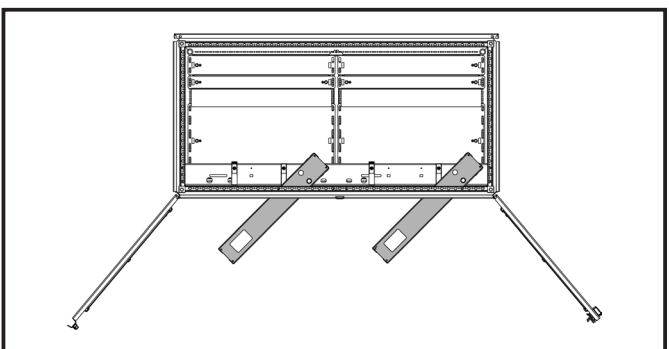
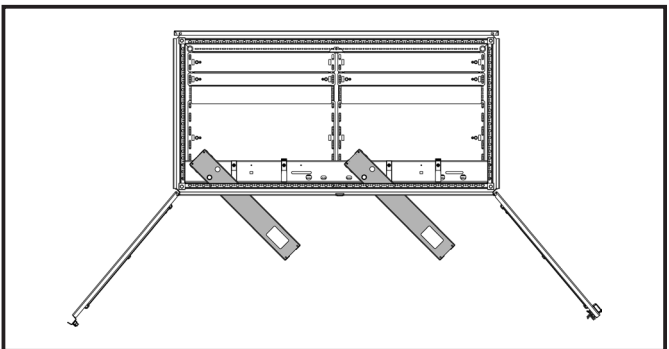
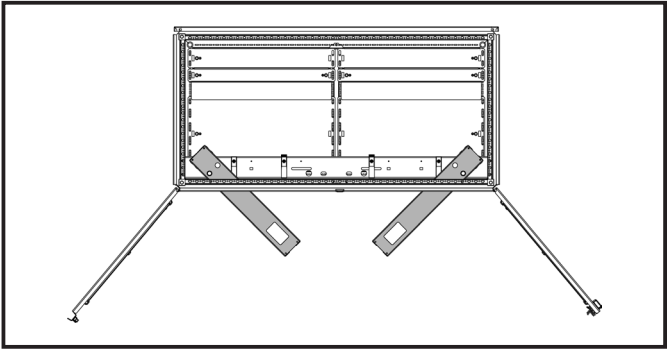
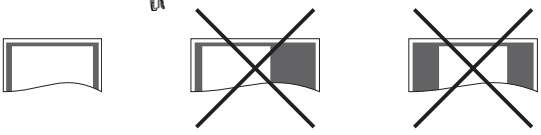
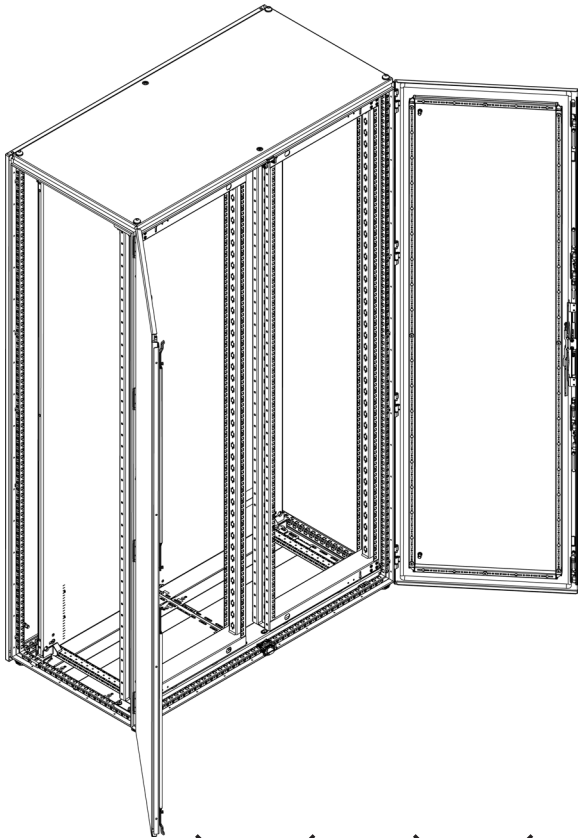

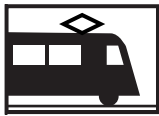
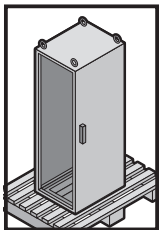

4. Transport  
4. Transport  
4. Transport



DE

Die Gehäuse müssen während Transport, Auf- und Ausbau gegen Umkippen gesichert werden. Bei Verwendung eines Sockelsystems ist beim Transport einschließlich dem Anheben und dem Absetzen darauf zu achten, dass die Last immer auf den Sockel-Eckstücken lastet und niemals auf den Sockelblenden.

EN

Enclosures must be secured against tipping over during transportation, assembly and installation. When using a base/plinth system, during transportation (including raising and lowering), ensure that the load is supported on the base/plinth corner pieces at all times, and never on the base/plinth trim.

FR

Lors du transport, du montage et de l'équipement, les armoires doivent être sécurisées pour ne pas basculer. Lors du transport y compris lors du levage et de la dépose des armoires avec socle, il faut veiller à ce que la charge repose toujours sur les pièces d'angle et jamais sur les plaques de socle.

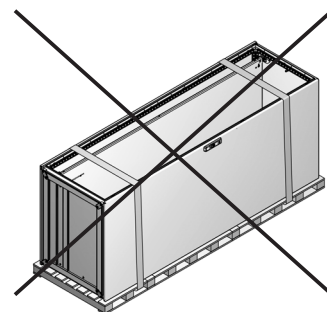
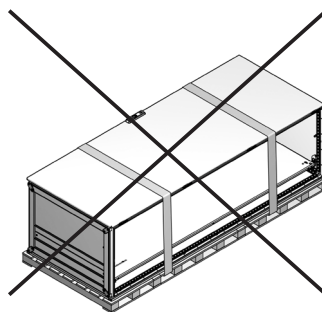
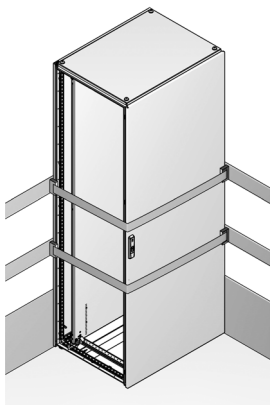



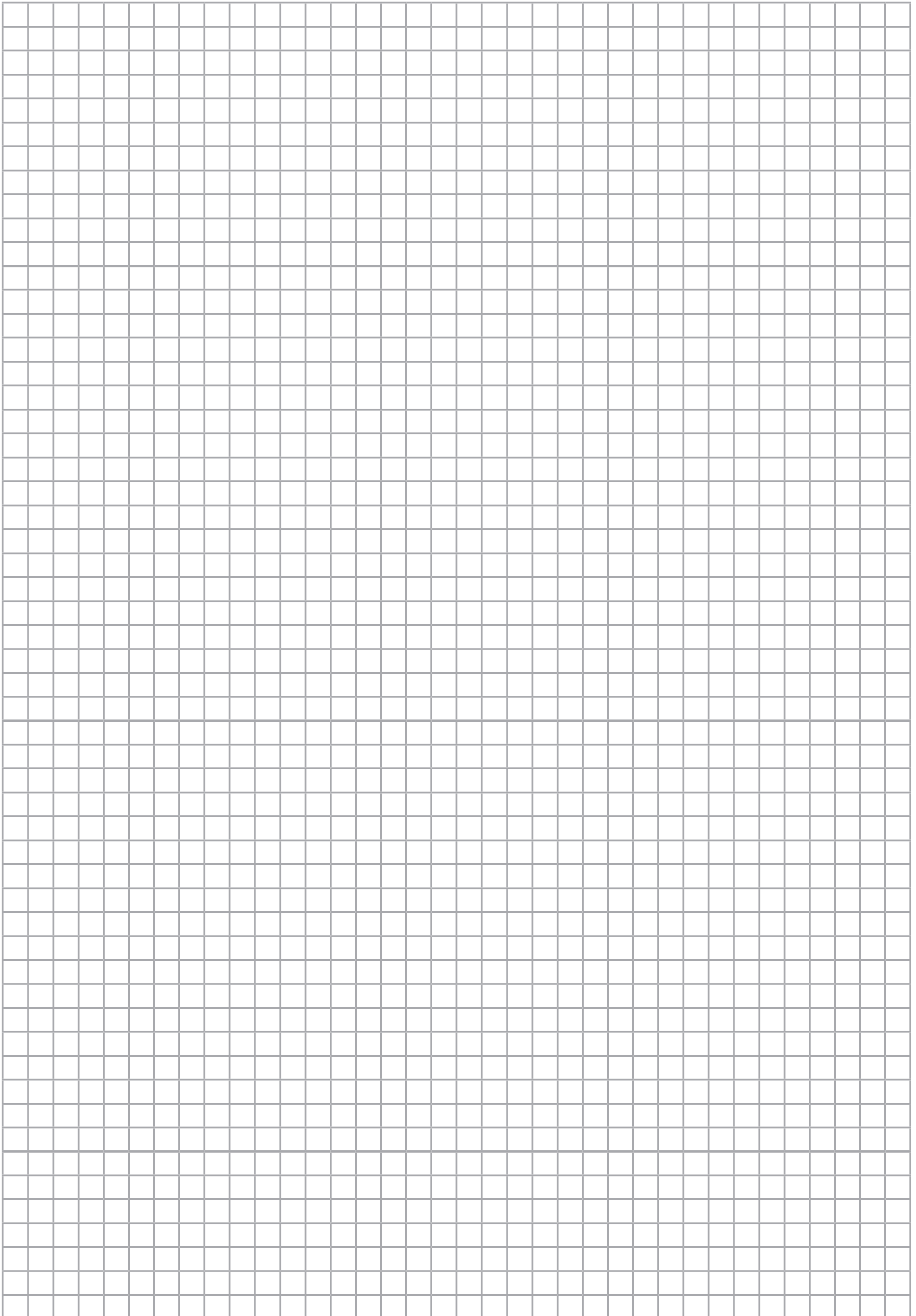

# Rittal – The System.

**Faster – better – everywhere.**

- Enclosures
- Power Distribution
- Climate Control
- IT Infrastructure
- Software & Services

You can find the contact details of all Rittal companies throughout the world here.



[www.rittal.com/contact](http://www.rittal.com/contact)

RITTAL GmbH & Co. KG  
Postfach 1662 · D-35726 Herborn  
Phone +49(0)2772 505-0 · Fax +49(0)2772 505-2319  
E-mail: [info@rittal.de](mailto:info@rittal.de) · [www.rittal.com](http://www.rittal.com)

10.20/D-0000-00001550-03

ENCLOSURES

POWER DISTRIBUTION

CLIMATE CONTROL

IT INFRASTRUCTURE

SOFTWARE & SERVICES

FRIEDHELM LOH GROUP

