

CS modular enclosures

Catalogue 33, page 208, 209

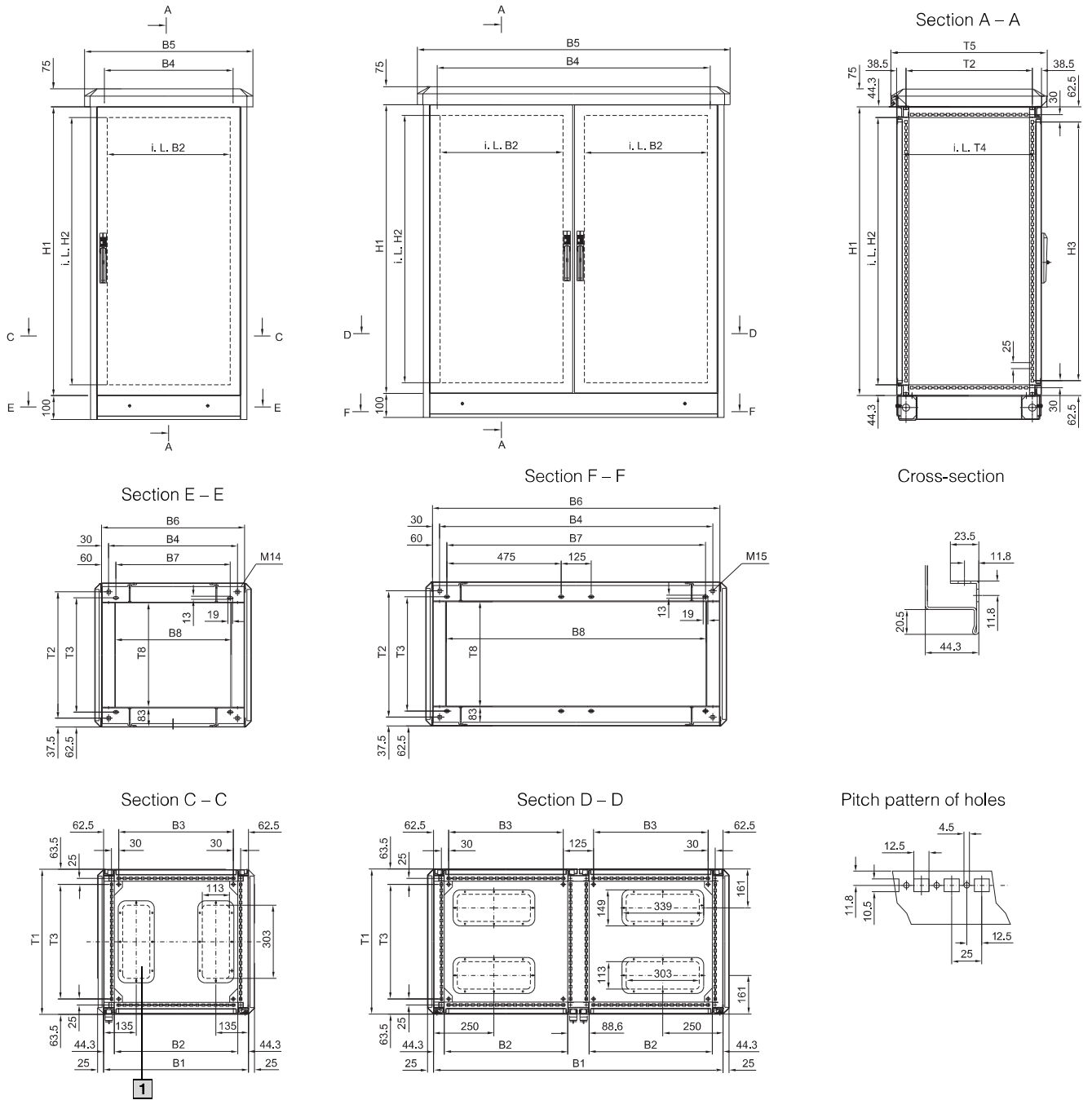

1 From an enclosure width of 800 mm
4 gland plates

Enclosure	Width dimensions mm										Height dimensions mm			Depth dimensions mm							
	B1	B2	B3	B4	B5	B6	B7	B8	B9	B10	H1	H2	H3	T1	T2	T3	T4	T5	T6	T7	T8
9751.015	600	512	475	535	700	595	475	479	494	500	800	712	675	600	525	475	554	650	445	500	434
9751.075	600	512	475	535	700	595	475	479	494	500	1000	912	875	500	425	375	454	550	345	400	334
9751.025	600	512	475	535	700	595	475	479	494	500	1200	1112	1075	600	525	475	554	650	445	500	434
9751.035	600	512	475	535	700	595	475	479	494	500	1600	1512	1475	600	525	475	554	650	445	500	434
9751.085	800	712	675	735	900	795	675	679	694	700	1000	912	875	500	425	375	454	550	345	400	334
9751.045	800	712	675	735	900	795	675	679	694	700	1200	1112	1075	500	425	375	454	550	345	400	334
9751.055	800	712	675	735	900	795	675	679	694	700	1200	1112	1075	600	525	475	554	650	445	500	434
9751.065	800	712	675	735	900	795	675	679	694	700	1600	1512	1475	600	525	475	554	650	445	500	434
9752.015	1200	512	475	1135	1300	595	1075	1079	1094	500	1200	1112	1075	500	425	375	454	550	345	400	334
9752.025	1200	512	475	1135	1300	595	1075	1079	1094	500	1200	1112	1075	600	525	475	554	650	445	500	434

Enclosures

Outdoor enclosures

CS modular enclosures

Catalogue 33, page 208, 209

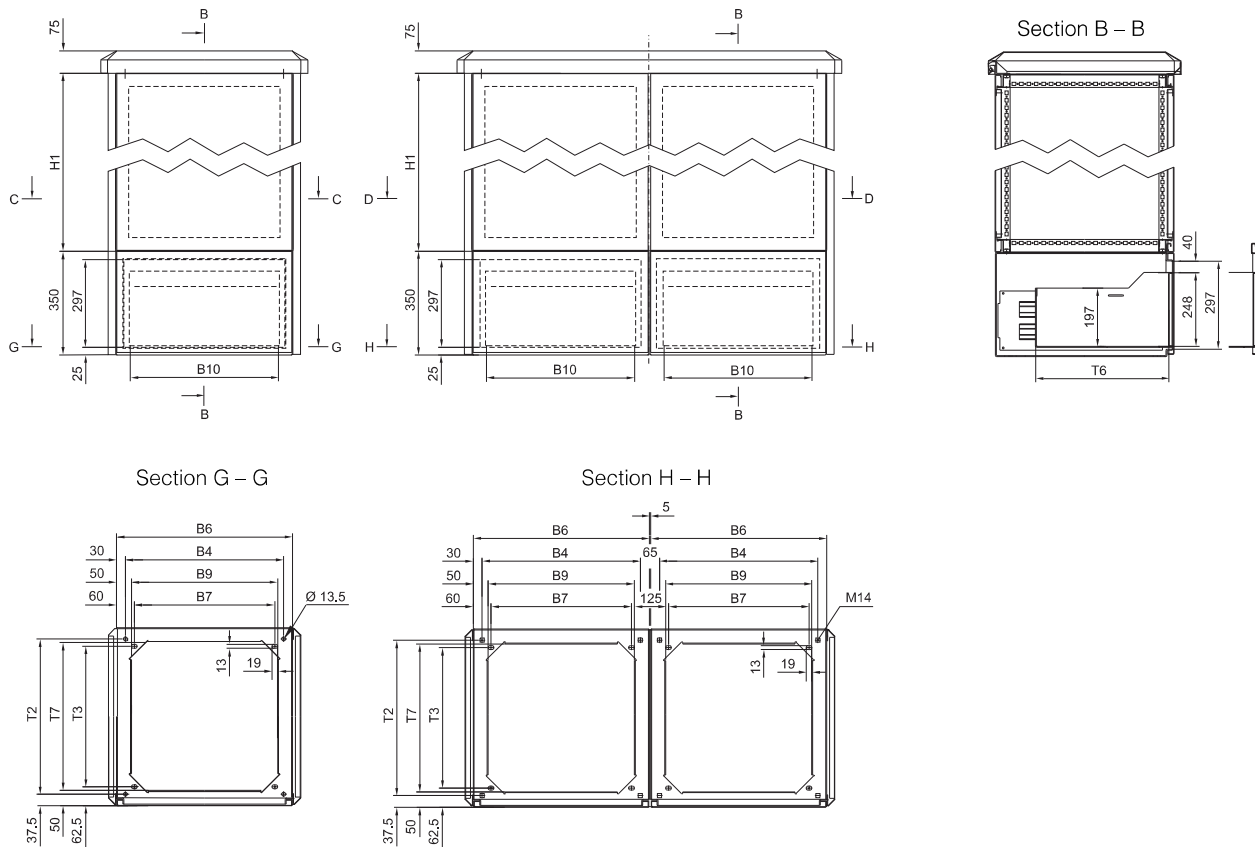

- B1 = Width of basic enclosure
- B2 = Clearance of enclosure frame
- B3 = Section length of system punchings
- B4 = Centre-to-centre distance between eyebolts
Hole distance base/plinth – base mount
- B5 = Width of roof (overall width)
- B6 = Width of standard and battery base/plinth
- B7 = Hole distance base/plinth – base mount
- B8 = Clearance of standard base/plinth opening
- B9 = Clearance of battery base/plinth opening
- B10 = Clearance width of battery drawer

- H1 = Height of basic enclosure
- H2 = Clearance of enclosure frame
- H3 = Section length of system punchings

- T1 = Depth of basic enclosure
- T2 = Centre-to-centre distance between eyebolts
Hole distance base/plinth – base mount
- T3 = Section length of system punchings
Hole distance base/plinth – base mount
- T4 = Maximum mounting depth
- T5 = Roof depth (overall depth)
- T6 = Clearance depth of battery drawer
- T7 = Clearance of battery base/plinth opening
- T8 = Clearance of standard base/plinth opening